

HAMILTON-SOUTHEASTERN UTILITIES, INC.

STANDARDS FOR

DESIGN AND CONSTRUCTION OF LATERALS

The ideas, designs, drawings and concepts contained herein are the exclusive intellectual property of Sanitary Management & Engineering Company, Inc. and are not to be used or reproduced in whole or in part, without the written consent of Sanitary Management & Engineering Company, Inc.

| | | |
|------|---|----|
| 1.01 | GENERAL..... | 3 |
| | A. Definitions..... | 3 |
| | B. Purpose..... | 3 |
| | C. Applicability..... | 4 |
| | D. Liability and Cost..... | 4 |
| | E. Standards, Specifications and Details | 4 |
| | F. Drawing Discrepancies and Omissions..... | 4 |
| | G. Governing Laws, Codes and Regulations | 5 |
| | H. Notices | 5 |
| | I. Confined Space Entry | 5 |
| | J. Maintenance..... | 5 |
| | K. Compliance | 5 |
| 1.02 | LATERALS | 5 |
| | A. Lateral Connection Permit | 6 |
| | B. Prohibition Against Clear Water Discharges | 7 |
| | C. Notice of Violation | 9 |
| | D. Mandatory Inspection of Building Connections | 9 |
| | E. Lateral Construction..... | 10 |
| | F. Lateral Length | 17 |
| | G. Maximum Number of Building Connections | 17 |
| | H. Owner’s Lateral Responsibility..... | 18 |
| | I. Protection of Water Supplies | 19 |
| | J. Connection of Existing Homes or Buildings | 20 |

Figure 1-1: Unacceptable Lateral Connection Detail

Figure 1-2: Acceptable Lateral Connection Detail

Figure 1-3: Typical Type 1 & 2 Clean-out Details
Figure 1-4: Typical Type 3 Clean-out Details
Figure 1-5: Service Lateral Detail
Figure 1-6: Sanitary Sewer Trenching, Bedding and Backfill Detail

Appendix A: Application for Connection Permit
Appendix B: Plot Plan Standards

1.01 GENERAL

A. Definitions

For the purposes of these Standards for Design and Construction of Laterals (“Standards”), the following definitions shall apply:

1. “HSE” shall mean Hamilton Southeastern Utilities, Inc., the public utility which provides sanitary sewer service in the Project (as hereafter defined) area. HSE’s address is 11901 Lakeside Drive, Fishers, Indiana 46038, and HSE’s phone number is (317) 577-2300.
2. “Engineer” shall mean the engineer for HSE, which is Sanitary Management & Engineering Company, Inc. (“SAMCO”) or SAMCO’s engineers. SAMCO’s inspector shall be the Engineer’s representative during construction of Laterals. SAMCO’s address is 11905 Lakeside Drive, Fishers, Indiana 46038, and SAMCO’s phone number is (317) 577-1150.
3. “Owner” shall mean the property owner of record whose deed is recorded at the Hamilton County Recorder’s office. This definition is intended to include all contractors, sub-contractors and/or agents acting for or on behalf of the Owner.
4. “Contractor” shall mean any construction contractor approved by HSE to construct, install, maintain, repair and remove Laterals (as hereafter defined) within the HSE service area. This definition is intended to include all employees, sub-contractors and/or agents acting for or on behalf of the Contractor’s company.
5. “Lateral” shall mean any pipe (gravity or force main) which runs from the Owner’s buildings, structures, property or premises (“Owner’s Premises”) to the main line sewer which receives sewage from the Owner’s Premises. Laterals are also commonly known as “service pipes,” “building sewers” and “service connections” but are herein referred to as Laterals.
6. “Project” shall mean any sanitary sewer facilities constructed within the service area of HSE and shall include all work necessary for the installation of all sanitary sewer infrastructure and appurtenances in conformity with HSE approved construction plans and the standards, specifications, and details of HSE.
7. “Conveyed” with regards to sanitary sewer facilities means Projects for which HSE has received title.
8. “Completed” with regards to Projects shall mean any Projects which are acceptably constructed, tested and through which customer service has been authorized by HSE. All applicable fees must be paid to HSE prior to a Project being deemed Completed.

B. Purpose

The purpose of these Standards is to provide the general rules and policies set forth for the construction of Laterals within the HSE service area. It is the intent of these Standards to

provide interested parties with a concise statement of the policies governing the sanitary sewer connection permit (“Permit”), construction and completion processes of Laterals.

C. Applicability

These Standards are applicable for all Laterals which will be connected to HSE’s sanitary sewer system. This includes Projects (including on-site disposal systems) which will not initially be connected to HSE’s sanitary sewer system but at some future date may be connected to the system.

D. Liability and Cost

No direction, field directive, or other instruction contemplated by these Standards and/or conducted by others shall accrue any liability, charge or cost to HSE, Engineer or Engineer’s inspectors. *The utility will not assume responsibility for noncompliance with the referenced specifications as a result of information not provided in these Specifications.*

E. Standards, Specifications and Details

1. These Standards and HSE’s other standards, specifications and details are subject to revision at any time prior to the start of construction of the Lateral. These documents are also subject to revision at any time during construction when, in Engineer’s opinion, those revisions materially affect the maintenance, operations or life of the Lateral.
2. HSE reserves the right to modify or waive any of these Standards and/or its other standards, specifications and details in its best interest.
3. These Standards are intended to define the construction requirements of Laterals which are constructed and operated under typical conditions in HSE’s service area. Depending on field conditions and the composition and characteristics of the sanitary sewer flow, different or unusual conditions may occur which cannot be anticipated in a document of this nature. Consequently, Engineer may impose additional or special construction requirements under such circumstances.

F. Drawing Discrepancies and Omissions

1. Prior to the start of construction, the Contractor must notify Engineer of any conflicts between the construction drawings, any supplemental information supplied by HSE and/or these Standards. Resolution of any such conflict shall be at the Engineer’s sole discretion.
2. Any items which are not covered in these Standards, the construction drawings or HSE’s other standards, specifications and details, but are required for construction of the Lateral, must be approved by Engineer prior to installation of the Lateral.
3. In the event construction practices are not described herein, but in Engineer’s opinion, will affect the quality of construction or maintenance of the Lateral, the

Engineer must approve any construction practices proposed by the Contractor.

G. Governing Laws, Codes and Regulations

1. Construction practices must meet all applicable laws, codes or regulations and be in accordance with the requirements of all governmental agencies and public entities having jurisdiction.
2. These Standards shall not be considered as a substitute, nor shall they supersede, any state or federal law, code or regulation related to construction of Laterals. In the event of a conflict between any state or federal law, code or regulation governing the design and/or construction of Laterals and these Standards, the more stringent requirement will apply.
3. All persons on site must abide by all Indiana Occupational Safety and Health Administration (“IOSHA”) standards including but not limited to “General Construction Practices” and “Trench Safety Standards.” The responsibility for safety measures rests solely with the Contractor. All excavations must adequately guard the public by barricades, fences, lights and other such means as necessary.

H. Notices

All notices required by these Standards must be given to both HSE and Engineer at their respective business offices.

I. Confined Space Entry

All persons, including but not limited to Owners, Contractors, sub-contractors, etc. must abide by HSE’s “General Procedures for Manhole Opening and Entry” or the most recent IOSHA confined space entry standards, whichever is more stringent.

J. Maintenance

Laterals must be maintained in compliance with HSE’s current “Maintenance Specifications for Sewer Facilities”

K. Compliance

1. Laterals must comply with the latest published edition of American Water Works Association (“AWWA”), American Society for Testing and Materials (“ASTM”), American National Standards Institute (“ANSI”) and Uni-Bell PVC Pipe Association (“UNI”) standards or as indicated in these Standards, whichever is more stringent.
2. Engineer’s decisions shall be final. Failure to comply with HSE’s standards, specifications, details or field directives/decisions shall be grounds for removal from the HSE approved contractor list.

1.02 LATERALS

A. Lateral Connection Permit

1. Connection Permits

A Permit must be issued by HSE for all repairs, modifications or connections to Laterals. In addition, Permits are required for expansions of existing buildings.

2. Minimum Elevations for Gravity Connection

Owner shall verify that the lowest elevation to have gravity sanitary sewer service within the home or building is more than one (1) foot above the lowest top of casting elevation of either the first upstream or downstream manhole on the main line sewer to which the connection is to be made. (See Figures 1-1 and 1-2). If the vertical separation can not be maintained, then the Owner must sign a Waiver of Responsibility which will be recorded against the deed of record.

Applicant should carefully consider the lowest elevation to have gravity sanitary service. For example, the invert of trench drains or the outlet of a swimming pool sump pit may potentially be the point of lowest elevation.

Prior to the installation of a Lateral, the Contractor shall field verify compliance with the minimum elevation for gravity connection.

If at the time of application for the permit an "As Built Top of Casting" elevation is not available then the lowest elevation to have gravity sanitary sewer service within the home or building must be set two (2) feet above the lowest "plan grade" shown for either the upstream or downstream manhole on the main line sewer to which the connection is to be made.

3. Permit Fee

A fee as defined in HSE's current tariff shall be charged on a per Equivalent Dwelling Unit ("EDU") for a Permit. Any re-inspection which may be necessary because of defective workmanship or incomplete construction will be assessed a re-inspection fee.

4. Application for Permit

A Permit application must be made on the form prescribed by HSE and available from the utility at 11901 Lakeside Drive, Fishers, IN 46038. An application is included in Appendix A.

All easements required by Engineer must be approved and recorded prior to issuance of the Permit.

The application will require at a minimum the following information:

- a. Name and address of the Owner;
- b. Name, address and telephone number of the Contractor;
- c. Address;
- d. If required, a legal description of the Owner's property for which the Permit is being requested;

- e. Plans for the Lateral and connection, which at a minimum must consist of the following:
 - (1) Plot Plan according to HSE's Plot Plan Standards. Refer to Appendix B;
 - (2) Connection details including location of connection and routing of the Lateral;
 - (3) Material of construction for the Lateral;
 - (4) Elevation of the first floor and lowest point of gravity service. All elevations must be on the same vertical datum as the HSE approved construction plans; therefore a conversion between different datum may be necessary.

5. Who May Apply

The following can only apply for a Permit:

- a. Home Builders
- b. Owner
- c. At the discretion of HSE, persons other than those listed above may apply for a Permit.

Note: HSE may deny Permits to any applicant who has previously violated, or is currently in violation of, these Standards or any other HSE rules, regulations, standards, specifications or details.

6. Expiration of Permit

- a. The Permit will expire if work is not initiated within one hundred eighty (180) days from the date of issuance. Upon expiration, a new Permit, including payment of the Permit fee, will be required.
- b. HSE may for good cause extend the duration of the Permit for a reasonable period. Requests for extension of the Permit period must be submitted in writing to HSE in advance of the expiration and must state the reason for the request. Requests for extension must be forwarded to:

HAMILTON-SOUTHEASTERN UTILITIES, INC.
11901 LAKESIDE DRIVE
FISHERS, IN 46038
ATTENTION: PERMIT TECHNICIAN

B. Prohibition Against Clear Water Discharges

- 1. The following sources of clear water shall not be connected to any Lateral:
 - a. Foundation/footing drains
 - b. Sump pumps with foundation drains or other clear water sources
 - c. Roof drains
 - d. Heat pump/Geo-Thermal discharge
 - e. Cooling water and/or
 - f. Any other sources of clear/unpolluted water

Any person found violating any provision listed above will be required to correct such connection at their expense and as directed by the Engineer within thirty (30) days of notification. Failure to comply may result in termination of service by HSE.

2. De-watering Discharge to a Sanitary Sewer
 - a. Keep excavations free from water until all sanitary sewer facilities are completed. Provide sufficient dikes and de-watering equipment and make satisfactory arrangements for the disposal of the water without undue interference with other work, damage to property or damage to the environment. Water disposal must be in compliance with the regulations of the Environmental Protection Agency (“EPA”), Indiana Department of Environmental Management (“IDEM”), Soil Conservation Service (“SCS”) and all other applicable agencies.
 - b. Contractor shall prevent all water from entering the Lateral. In the event any water enters Completed sanitary sewer facilities, the Contractor is responsible to HSE for the costs of sewage treatment, electrical power, equipment repairs, incidental damages, cleaning and any other costs or expenses related to such entry. In addition, Contractor shall pay HSE damages of \$300 per occurrence.
 - c. Contractor must, at Engineer’s discretion, provide de-watering equipment, shoring or other construction practices deemed necessary by Engineer.
3. In the event a home or building has a floor drain or trench drain connected into the Lateral, all site grading must prevent surface water from discharging into the sanitary sewers. Also, when floor drains or trench drains are installed in rooms with exterior connections, either a three (3) inch sill must be added to the exterior doors or the finished floor elevation of the rooms must be installed three (3) inches above surrounding finished grade.
4. HSE requires that all Laterals shall be subject to video camera inspection at the time of initial installation. At the Engineer’s discretion, Laterals may also be inspected by video camera at any time after the initial installation. In addition to the above video camera inspection, the Engineer may require the following additional tests to identify sources of inflow/infiltration (I/I):
 - a. Low pressure air test
 - b. Smoke testing
 - c. Dye test
 - d. Vacuum test of manhole
 - e. Flow monitoring
5. In the event an industrial or commercial entity finds it necessary to discharge clear water consisting of cooling water and/or steam condensate into HSE’s sanitary sewer system and the main line sewer has capacity to receive such clear water without affecting existing or future users, then HSE may enter into an agreement

for such discharge. The agreement will define a metering system and any other requirements deemed necessary to measure the flow. The user rate for such discharges will be calculated as provided by HSE's established rate schedule.

C. Notice of Violation

HSE will issue a "Notice of Violation" whenever it determines that:

1. Construction is proceeding in an unsafe manner; or
2. Construction is occurring in violation of these Standards and/or any other applicable HSE standards, specifications or details; or
3. Sewer construction for which a Permit is required is proceeding without a Permit being in force; or
4. Connection of any source for clear water to the Lateral; or
5. A discharge, into HSE's sanitary sewer system, of any prohibited water or wastes as defined in the "Rules and Regulations of Hamilton Southeastern Utilities, Inc." as approved by the Indiana Utility Regulatory Commission ("IURC").

The Notice of Violation will be in writing and will indicate the location and reason for its issuance. One (1) copy of the Notice of Violation will be posted on the property in a conspicuous place and one (1) copy will be delivered to the Permit holder. HSE may refuse to provide sanitary sewer disposal service or refuse to allow work to resume until Engineer issues a written notice of proper compliance.

D. Mandatory Inspection of Building Connections

1. Notification

It shall be the duty of the holder of a Permit to notify HSE that the sewer work is available for inspection. Notification must be provided at least seventy-two (72) hours before inspection is desired. Engineer will conduct inspections on Laterals from 8:00 a.m. to 3:00 p.m. local time, Monday through Friday, except for observed holidays.

The Contractor will be responsible for ensuring that the following items have been completed prior to scheduling the Hook-up:

- a. *Contract for sewer service has been executed.*
- b. *Approved Plot Plan in HSE scanned document file.*
- c. *The HSE connection permit has been issued.*
- d. *All fees have been paid.*

The Lateral, in its entirety from the foundation to the connection with the public sewer or existing lateral must be exposed for inspection and be constructed in accordance with these Standards. Under no circumstances shall the Lateral be backfilled without an inspection by Engineer.

2. Video Camera Inspection

- a. Within 90 days after initial installation, each Lateral shall be inspected by video camera. Engineer shall perform the video camera inspection and inspect for the following:
 - (1) Joint separation/off-set joint.
 - (2) Construction debris (stone, broken pipe, mud, etc.) in Lateral or main line sewer.
 - (3) Properly installed joints.
 - (4) Deformed pipe.
 - (5) Cracks in pipe.
 - (6) Infiltration.
 - (7) Number of fittings and distance between clean-outs.
- b. At the sole discretion of Engineer, Contractor may be required to clean, repair or replace defects identified during the video camera inspection.
- c. Depending on the type of defects identified during the above video camera inspection or the type of repair, Engineer may also require Contractor to perform a low-pressure air test of the Lateral or an individual joint.

3. Right of Entry

Engineer shall have the right of entry to, upon or through the Owner's Premises for purposes of inspection of Laterals or to determine if any sources of clear water are connected to the Lateral.

E. Lateral Construction

1. Materials

- a. Pipe and fittings used in Lateral construction shall be smooth wall inside and out, and must be either: Polyvinyl Chloride ("PVC") and must conform to ASTM D-3034 (SDR 35 or SDR 26 or SDR 23.5) (*fittings must be SDR 26 minimum wall thickness*), Type PSM or CAN/CSA-B182.2.M90, the more stringent shall apply; or ASTM D-2241 (SDR 21); or ASTM D-1785 (Schedules 40 or 80). Minimum cell classification of pipe must be 12454-B or 12454-C or 13364-B or 12364-C as defined by ASTM D-1784. All pipe must have a minimum tensile strength of 34.50 MPa as defined by ASTM D-1784.

or

Ductile iron ("DI") pipe must meet ASTM A-746 (pressure class 350) or AWWA C-151 (pressure class 350) with exterior asphaltic coating per AWWA C-151 and interior asphaltic coating meeting AWWA C-151 or polyethylene lining complying with ASTM D-1248 of nominal 40-mil thickness. Thickness design must be in accordance with AWWA C-150.

Or

HDPE pipe must meet ASTM D3350 and meet HSE standard for Horizontal Directional Drilling and Piping.

b. Transition to and from different pipe types or materials types must be with ductile iron, mechanical joint (“MJ”) solid sleeve fittings with transition gaskets.

c. Joints must be either:

Flexible gasket push-on compression type for PVC pipe. The joint must comply with ASTM F-477, and the physical requirements of ASTM D-3212, and UNI-B-1 “Recommended Specifications for Thermoplastic Pipe Joints. Pressure and Non-Pressure.”, the more stringent shall apply. The gasket must be the only element depended upon to make the joint flexible and watertight.

or

Solvent cement type with colored primer assembled in a manner directed by Engineer for PVC pipe.

Do not use primer or cement that is gelled. Cut the pipe square and remove all burrs and beads. Clean with a dry rag and check fit prior to adding cement.

Install primer aggressively and keep wet, do not allow puddling. Apply first to inside surface, then to outside surface and then repeat to inside surface.

Cement is to be installed while primer is still wet. Apply first to outside surface then to inside surface and then repeat to outside surface.

Assemble while wet and turn ¼ revolution to evenly distribute. Hold in place for 1 minute. Clean off excess cement and allow to cure properly (in cold weather, more time and additional applications are required. i.e. 4 hour minimum at 20° F).

Solvent welding procedures to comply with ASTM D2855 and D1785.

or

Joints on DI pipe must be the integral bell type gasketed joint meeting AWWA C-111, MJ meeting AWWA C-111, or ANSI 125 lb. flanged joint. Accessories for mechanical and flanged joints must be alloy steel

“T”-head bolt and hex nut of Coarse Thread Series Class 2A (External) and Class 2B (internal) per ANSI B1.1.

or

HDPE pipe joints to be fusion welded and meet ASTM D3261. They must be made by an experienced installer and meet all HSE standards for HDPE pipe.

2. Installation of Laterals

a. Permit

A Permit must be issued by HSE prior to the installation of a Lateral.

b. Approved Contractors

- (1) Contractors pre-approved by HSE must construct Laterals. Any Lateral installed by contractors not pre-approved by HSE will be rejected. A list of pre-approved contractors may be obtained at HSE's office.
- (2) Approved Contractors shall not sub-contract Lateral installation work to anyone other than an HSE approved Contractor.
- (3) Each supervisor, foreman or superintendent and pipe layer assigned by Contractor to supervise on-site installation of Laterals shall also be pre-approved by HSE *and be recertified annually*.
- (4) To maintain approval by HSE, a Contractor must install a minimum of ten (10) Laterals per calendar year.
- (5) *Approved Contractors must submit a Standardized Pre-Qualifications Form (PQF) annually to maintain approval.*

c. Minimum Size, Fittings and Clean-outs

- (1) Laterals must be a minimum of six (6) inches in diameter and sized based on the anticipated flows. For example, a lateral servicing a pool house may need to be larger based on the peak filter backwash flow. Laterals must have a wye clean-out located within three (3) feet of the building's exterior wall and subsequent clean-outs must be installed at a maximum interval of one hundred (100) feet. Therefore no section of Lateral between the building and main line sewer shall exceed one hundred (100) feet without the installation of a clean-out.
- (2) It is recommended that a clean-out be installed after every three (3) fittings of 22.5 degrees or more, but in no case exceeding five (5) fittings between clean-outs. All fittings must be 45 degrees or less. Engineer will not permit fittings of greater than 45 degrees. Also, when deemed necessary by the Engineer a clean-out must be installed.
- (3) All clean-outs must be the same diameter as the horizontal Lateral

- into which the clean-out is connected; minimum of six (6) inches.
- (4) All clean-outs must be extended to grade and capped per HSE's requirements. Clean-outs installed in grass or landscape areas **and** located within three (3) feet of the buildings exterior wall must be installed per clean-out Type 1 of Figure 1-3. All other clean-outs must be installed per clean-out Type 2 or Type 3 of Figure 1-3 and 1-4. In order to avoid cap damage, Engineer will also require that all clean-outs installed greater than three (3) feet from the buildings exterior wall be installed as Type 2 in hard surface area or a Type 3 in landscape or grass area. Under no circumstances shall clean-outs be buried. If the lateral extends above the Building Foundation then compacted granular backfill must be installed per figure 1-6. HSE Approved Contractor shall be solely responsible for installation and compaction of granular material. Any future settlement of Lateral or damage caused by settlement shall be the sole responsibility of HSE Approved Contractor.
- (5) Fiber mesh reinforcement for Type 2 clean-outs: Application per cubic yard shall equal a minimum of 1.5 pounds. Fibers are for the control of the following: cracking due to drying shrinkage and thermal expansion/contraction, to lower concrete permeability and to increase impact capacity, shatter resistance and abrasion resistance. Fibermesh, 4019 Industry Drive, Chattanooga, Tennessee, 37416 or equal as approved by Engineer on a case by case basis, must manufacture fiber mesh reinforcement.

d. Slope

- (1) Slope requirements must conform to the latest edition of the State of Indiana (Uniform Plumbing Code), local codes and to these Standards, whichever is more stringent.
- (2) Laterals must be installed at a minimum of 1.00% and where possible, not exceed 6.00%. Engineer, depending on site conditions, may waive the slope requirements.

e. Connection to Main Line Sewer

- (1) Laterals are not allowed beyond those installed during original construction and must connect to the sanitary sewer only at manufactured fittings (except as otherwise permitted by these Standards). No saddle connections to the sanitary sewer will be allowed.
- (2) Laterals must not connect directly into any manhole without the prior written approval of HSE. If approved, Laterals must connect to the manhole at an elevation of not more than twenty-four (24) inches above the base of the manhole. Inside drop connections to manholes are not permitted.

f. Lateral Stubs

Laterals installed for future connections must be terminated at the right-of-way or easement and plugged to ensure water tightness. A standard 2" x 4" with the top four (4) feet painted green must be installed at the end of the plugged line. The 2" x 4" must extend from the top of the lateral to four (4) feet above finished grade. *Depth to lateral and lot or block number to be shown on marker.*

g. Laying Laterals

- (1) The point of commencement for Laterals must be at the connection to the main line sewer and must be laid with the bell end pointing upgrade. Installation must be per Figure 1-4.
- (2) Unless the prior written approval of Engineer is obtained, Contractor shall not intermingle differing sizes, types, classifications or grades of pipe in the same Lateral installation.
- (3) *Laterals are to be installed with an insulated #10 copper tracer wire from the wye to the final cleanout at the structure.*
- (4) The foundation wall which the Lateral penetrates must be constructed prior to installation of the Lateral.
- (5) *Laterals that parallel a portion of a structure must be a minimum of five feet from the face of the structure (house and/or garage). When the lateral parallels the porch a three foot separation must be maintained.*
- (6) *It is recommended that laterals not enter a structure through/under the garage and may do so only with the permission of the Engineer.*
- (7) Within the subject lot or parcel, Laterals must be installed to maintain a minimum separation of ten (10) feet from boundary lines. Additional separation may be required based upon the depth of the Lateral and/or soil/groundwater conditions.
- (8) Laterals shall be located to avoid the following situations:
 - (i) Installation below pavement or concrete, including streets, driveways, parking lots, etc.
 - (ii) Installation below storm sewers or water ways.
 - (iii) Installation below other utilities.
 - (iv) Installation below mounding, landscaping, and retaining/landscaping/entrance walls.
 - (v) Horizontal separations from utilities, streets, storm sewers, water ways, buildings, etc. of less than ten (10) feet.
- (9) Refer to the subsection titled, Laterals under the Design Requirements section of HSE's Design Specifications for Sanitary Sewer Facilities for further information.
- (10) Laterals must be installed as previously stated and as per UNI-B-5 "Recommended Practice for the Installation of Polyvinyl Chloride (PVC) Sewer Pipe", the more stringent shall apply.

- h. *Locator Wire*
- (1) *Mainline contractor is to install insulated #10 copper tracer wire along the top of pipe from the wye to the lateral marker. At the marker the wire is to be extended to the surface.*
 - (2) *Lateral contractor is to connect to the tracer wire at the marker and extend the wire along the top of pipe to the cleanout adjacent to the structure.*
- i. *Wye and First Pipe for Deep Mainlines*
- (1) *From the wye installed on the sewer main the first length of pipe on all long side laterals must be laid upon undisturbed ground, bedded in a minimum of six (6) inches of #8 stone. The first length of pipe for the short side lateral may be laid upon fill made up of #8 stone. If the sewer is deeper than 25 feet then both long side and short side laterals may not be laid at a slope greater than 45 degrees*
- j. *Bedding and Backfill*
- (1) Bedding and backfill must meet all requirements set in Figure 1-6 of these Standards and the manufacturer's recommendations, whichever is more stringent.
 - (2) To prevent or minimize trench settling and consequently Lateral failure, the Contractor shall place granular backfill compacted to 95% modified proctor density vertically from the building foundation to the #8 stone pipe bedding; and horizontally from the foundation wall to undisturbed earth.
- k. *Cover and Concrete Capping/Encasement*
- (1) Laterals must maintain a minimum cover (from finished grade to top of pipe) of five (5) feet within all right-of-ways or easements. If minimum cover cannot be maintained, then a concrete cap must be installed when cover is four (4) to five (5) feet and concrete encasement must be installed when cover is three (3) to four (4) feet. Engineer will not accept Laterals installed with less than three (3) feet of cover inside all right-of-ways or easements.
 - (2) Upon exiting the building, the Lateral must maintain a minimum cover (from finished grade to top of pipe) of three (3) feet. Cover must be a minimum of three (3) feet, immediately downstream of the building's exterior clean-out. Laterals with less than two (2) feet of cover at the building will not be accepted by HSE.
 - (3) Laterals with less than eighteen (18) inches of vertical separation from other utilities or crossing below streams and other drainage ways must be concrete encased/capped.
 - (4) Based on existing or anticipated field conditions, Engineer may require concrete encasement or capping of the Lateral.

- (5) Refer to the Concrete Encasement and Concrete Cap details of HSE's Gravity Sanitary Sewer Details sheet.

3. Installation of I & A Systems, Grinder Pumps and Sewage Ejectors to Lateral

- a. HSE will allow the use of a sewage ejector only when it serves the level below grade and the balance of the house is served by gravity. If the entire residence flows to a pumped system, then an *I & A Tank* or grinder pump must be installed.
- b. *HSE will only allow the use of a grinder pump for a single residence that is connected directly into a gravity sewer and no other future connections are contemplated.*
- c. It is highly recommended that pumps be external to the building. Sewage backups into the wet well/building may occur due to failure of the pump, check valve or appurtenances, thus allowing sewage to flow into the wet well/building. Any backup into the wet well/building will be the sole responsibility of the Owner. HSE is not liable or responsible in any way for damages due to sewage backups in wet wells/buildings served by grinder/ejector pumps.
- d. All pumps must have high level alarm, check valve and shutoff valve suitable for sewage applications.
- e. All *I & A Tanks*, grinder pumps and effluent pumps must have an electrical disconnect switch, approved by HSE, mounted adjacent to the wet well.
- f. All piping or facilities installed exterior to the building must be installed by an HSE approved Contractor.
- g. All exposed piping must be Schedule 40 galvanized steel.
- h. All buried piping must be a minimum of either PVC SDR 21 conforming to ASTM D-2241, PE DR 11, or Schedule 40 conforming to ASTM D-1785.
- i. Galvanized pipe must be threaded connections and PVC pipe must be either solvent weld or gasketed push on joint connections conforming to ASTM D-3139 or AWWA C-900.
- j. The pump discharge must connect to the Lateral or common force main at locations approved by HSE in writing.
- k. Force main connections to HSE's sanitary sewer facilities shall be allowed only as approved by HSE in writing.

- l. Wet well/sump must be FRP or concrete and must be specifically designed for this application. The wet well shall be constructed as specified in HSE's specifications and details to prevent infiltration or inflow. Engineer may require vacuum testing of the wet well/sump. Refer to the Manhole Testing section of HSE's Gravity Sanitary Sewer Specifications sheet for further information on vacuum testing. Engineer will not permit the use of septic tanks connected to the sanitary sewer.
- m. The operation, maintenance, repair and replacement of the pump and appurtenances shall be the sole responsibility of the Owner. This also includes the force main and/or gravity Lateral from the building to its connection into the sanitary sewer main.
- n. Installation must conform to all national, state, and local building codes.
- o. The top of the wet well/sump must be:
 - (1) Eighteen (18) inches above the *current published DNR* 100 year flood elevation of nearby waterways.
 - (2) And it is highly recommended to be one (1) foot below the lowest elevation to have sanitary service in the home or building.
 - (3) *If the owner chooses not to maintain the standards for elevation of the top of the wet well/sump then a Waiver of Responsibility must be recorded.*

F. Lateral Length

1. If a Lateral must cross property owned by another entity other than the Owner, then the Lateral must be constructed in a dedicated easement approved by Engineer. A Permit will not be issued until the easement has been approved by Engineer and recorded.
2. Unless HSE, in writing, determines that an exception is justified, no more than one hundred (100) feet of a Lateral shall exist outside of the boundary of the lot or tract for which the Lateral is designed to service.
3. No Lateral shall be greater than two hundred (200) feet in overall length unless the prior written approval of Engineer is obtained.
4. As stated above, no section of Lateral shall exceed one hundred (100) feet without the installation of a clean-out.

G. Maximum Number of Building Connections

1. No more than one (1) building or residence will be permitted to connect into a lateral unless the prior written approval of Engineer is obtained.
2. *Except two existing residences may be served from one lateral.*

H. Owner's Lateral Responsibility

1. All costs for initial installation, subsequent repair, relocation, change or replacement of Laterals shall be at the Owner's expense.
2. Owner *may* place or permit to be placed any trees or other deep rooted landscaping *with separation as specified in the current (at the time of planting) HSE Approved Tree List. For trees not listed in the HSE Approved Tree List a Minimum separation of ten (10) foot horizontal distance for Laterals or any other sanitary sewer facilities (as measured from the drip line of the mature tree to the center of sanitary sewer facilities) must be maintained.* Any trees or landscaping placed within easements or right-of-ways are at risk of being damaged or removed by HSE without the obligation of replacement.
3. Owner shall not place or permit to be placed any mounding, lighting, fencing, signs, retaining/landscaping/entrance walls, irrigation lines, etc. directly over or within ten (10) foot horizontal distance of Laterals or any other sanitary sewer facilities (as measured from the nearest edge to the center of sanitary sewer facilities). Any of the above listed items placed within easements or right-of-ways are at risk of being damaged or removed by HSE without the obligation of replacement.
4. Prior written approval by HSE must be obtained for all grade changes across sanitary sewer facilities located within easements or right-of-ways.
5. Extreme care must be taken while landscaping or excavating to protect the Lateral from damage. Contact *Indiana Underground Plant Protection Service at 1-800-382-5544* prior to commencing such work.
6. It shall also be the responsibility of the Owner to insure that all manhole and clean-out top of castings extend a minimum of 0.20 feet above finished grade and are not buried, sodded over, placed in concrete or pavement (including driveways and sidewalks), or obstructed in any way. Manhole top of castings must have a minimum of one (1) foot separation from sidewalks and driveways. If a casting must be raised to comply with HSE's standards, Engineer will not permit more than a total of twelve (12) inches of riser rings in that structure. In the event the desired elevation can not be obtained without more than a total of twelve (12) inches of riser rings, it will be the responsibility of the Owner to add additional barrel sections to the structure. This work must be performed by an HSE approved Contractor and tested in compliance with HSE's Gravity Sanitary Sewer Specifications. Raising top of casting elevations may affect the minimum elevation for gravity connection for multiple lots or connections as described in these Standards.
7. Engineer may periodically perform field inspections to verify compliance with the above mentioned requirements. If a violation exists then the Owner must

immediately remedy the situation.

8. In the event, Engineer determines that a violation, as previously described, exists within Owner's Premises, Engineer will notify the Owner in writing. The notice will describe the nature of the violation and the corrective action(s) which must be taken. Such corrective action must be taken within thirty (30) days of receipt of such notice or the Owner may risk termination of sanitary sewer disposal service by HSE.
9. Trees or shrubs can not be planted directly over building laterals.
10. Based on the Ultimate Depth, mounding installed parallel to a sewer must be designed to maintain the same minimum horizontal separations as those indicated for Utility Separation and Utility Crossings in this section of these Design Specifications.
11. Mounding, even when crossing at ninety (90) degrees, must not be constructed directly over sanitary sewer facilities.

I. Protection of Water Supplies

1. There shall be no physical connections between a Lateral and the water supply system or appurtenances thereto which would permit the passage of any polluted water into the potable water supply. Laterals shall be laid at least ten (10) feet horizontally from any existing or proposed water line. The distance shall be measured edge to edge. In cases where it is not practical to maintain a ten (10) foot separation, the appropriate public health agency may allow deviation on a case-by-case basis. Such deviation may allow installation of the sewer closer to a water line, provided that:
 - a. The water line is in a separate trench or on an undisturbed earth shelf located to one side of the sewer, and
 - b. At an elevation so the bottom of the water line is at least eighteen (18) inches above the top of the sewer.
 - c. The lateral pipe must be constructed from water grade pressure pipe.
2. Laterals crossing water mains shall be laid to provide a minimum vertical separation distance of eighteen (18) inches between the outside of the water main and the outside of the sewer. This shall be the case where the water main is either above or below the sewer. The crossing shall be arranged so that the sewer joints will be equidistant and as far as possible from the water line joints. Where a water line crosses under a sewer, adequate structural support shall be provided for the sewer to prevent damage to the water line. When it is impossible to obtain proper horizontal and vertical separation as stipulated above, the Lateral shall be designed and constructed equal to water pipe, and shall be pressure tested to assure water tightness prior to backfilling.

3. Sewer/water supply separations and pipe classifications must conform with 327 IAC 3-6-9.

J. Connection of Existing Homes or Buildings

1. In order to obtain sanitary sewer service, Engineer may require all existing homes or buildings to construct a new Lateral, in accordance with these Standards, from the structure's foundation to the connection into the main line sewer.
2. Engineer does not normally permit Lateral connections to a main line sewer beyond those installed during original construction; therefore it is imperative that the Owner contact HSE during the design process of the main line sewer.
3. An exception will be made to these policies if the existing sewage disposal system was constructed in accordance with these Standards and inspected and approved by HSE or Engineer. Inspection services will be billed at HSE's current rate to the entity requesting inspection. Prior to connection of an existing system, HSE may require, at its Engineer's discretion, the following testing to identify potential sources of inflow/infiltration (I/I):
 - a. Low-pressure air test and/or vacuum manhole test (for sewers without Laterals) according to the HSE's Sanitary Sewer Standard Specifications.
 - b. Video camera inspection and/or smoke testing of all lines in the presence of HSE or Engineer.
 - c. Site inspection of the Owner's Premises, including the interior of buildings.

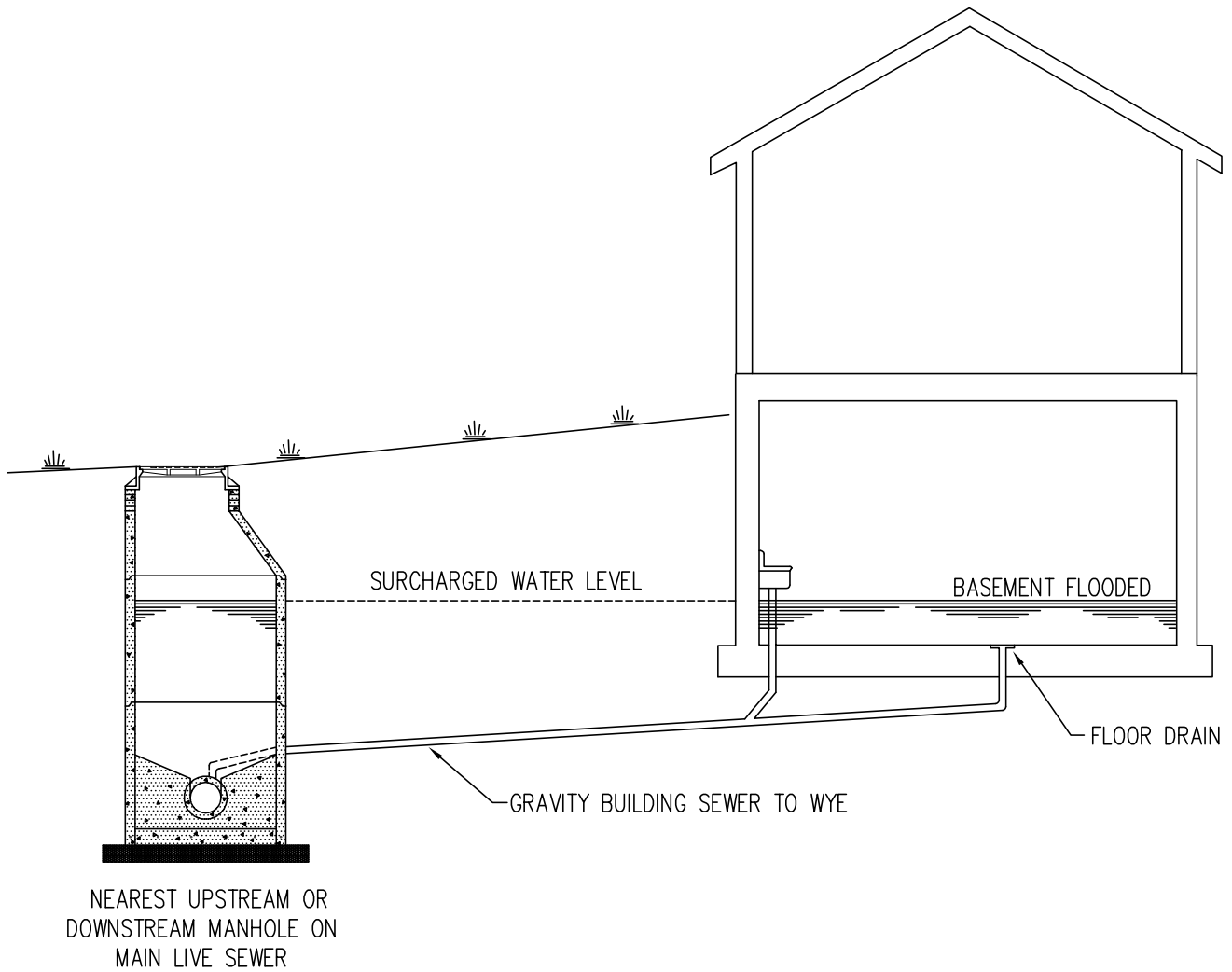

A SANITARY SEWER BUILDING CONNECTION CONSTRUCTED IN THIS SITUATION WILL NOT BE ACCEPTED (SEE THE ACCEPTED SITUATION - FIGURE 1-2)

UNACCEPTABLE BUILDING SEWER CONNECTION DETAIL

FIGURE 1-1

MANHOLE RIM MUST BE AT LEAST (1) ONE FOOT BELOW LOWEST ELEVATION TO HAVE GRAVITY SANITARY SEWER SERVICE.

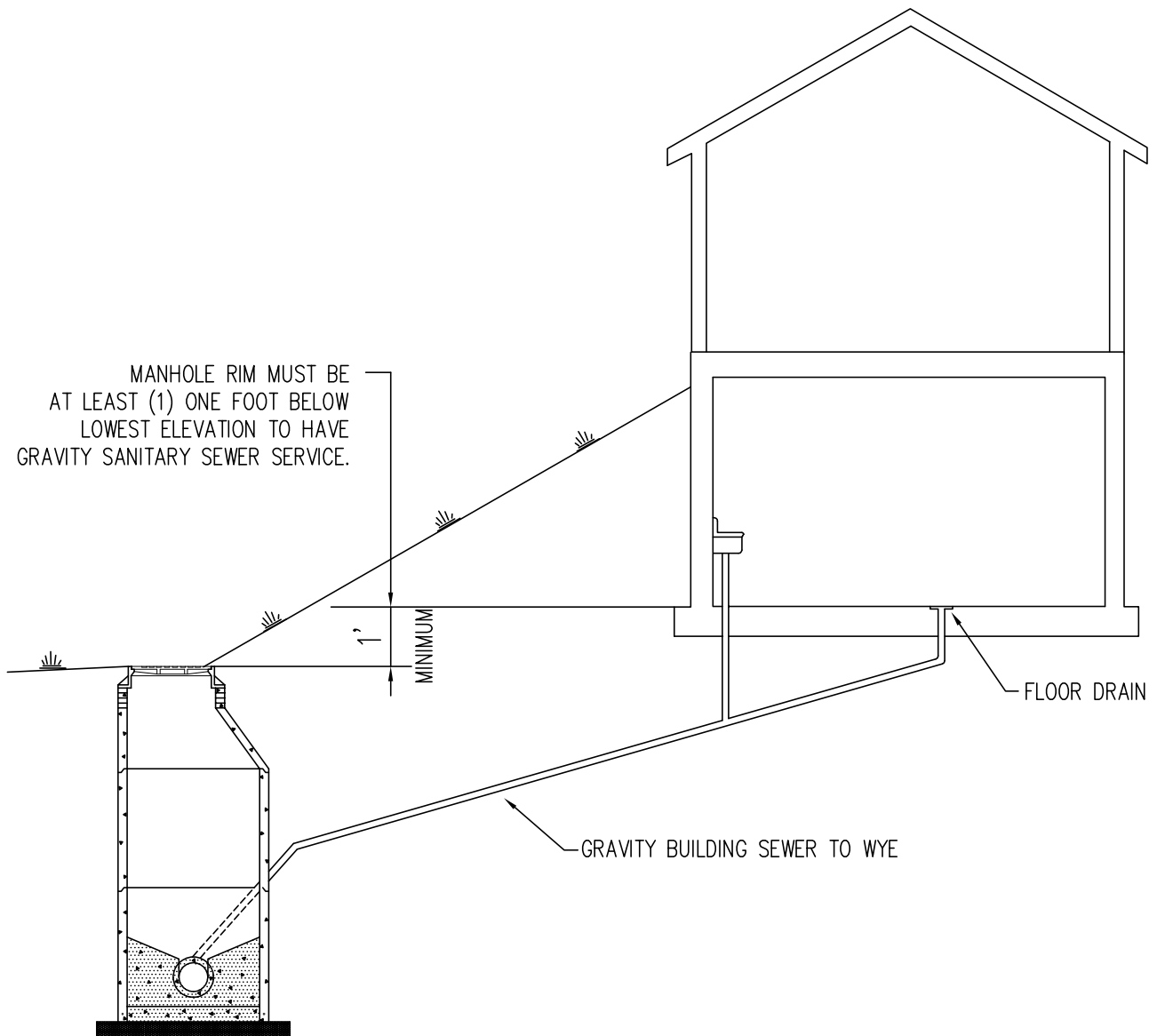

NEAREST UPSTREAM OR DOWNSTREAM MANHOLE ON MAIN LINE SEWER

ACCEPTED DESIGN OF SANITARY SEWER BUILDING CONNECTION (SEE THE REJECTED DESIGN – FIGURE 1-1)

ACCEPTABLE BUILDING SEWER CONNECTION DETAIL

FIGURE 1-2

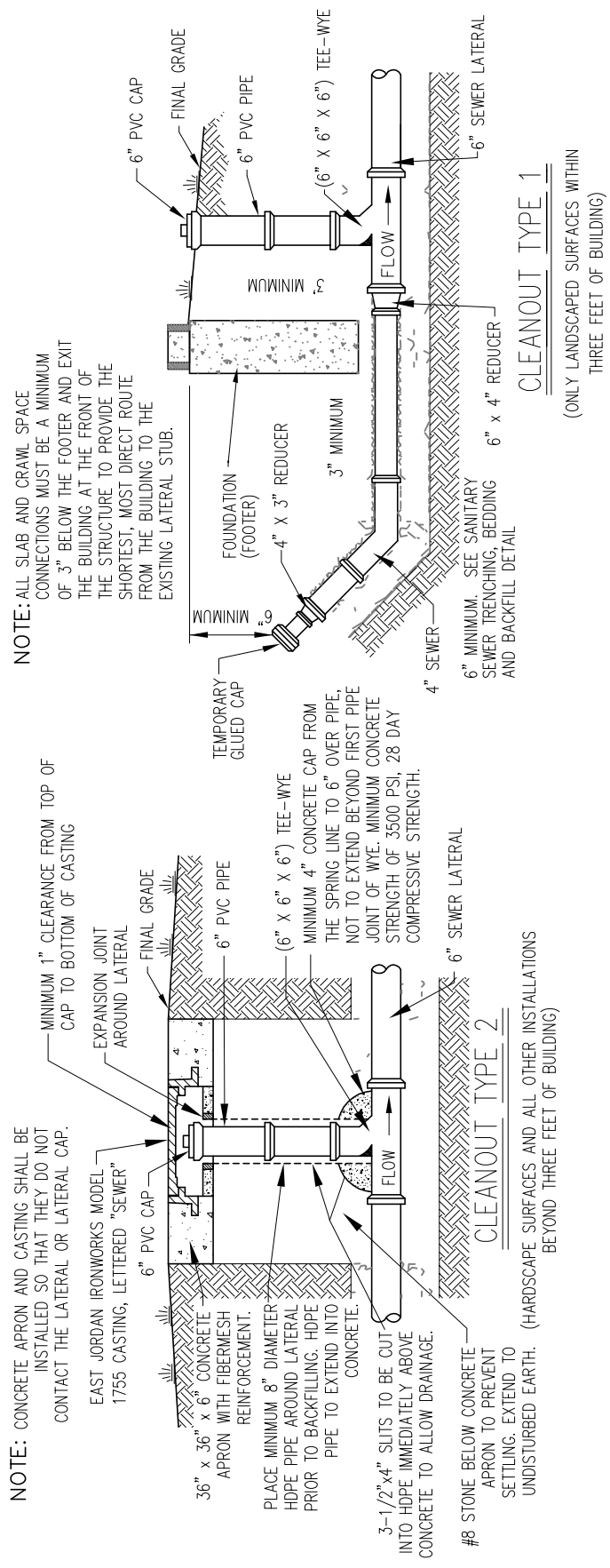

NOTE: ALL SLAB AND CRAWL SPACE CONNECTIONS MUST BE A MINIMUM OF 3" BELOW THE FOOTER AND EXIT THE BUILDING AT THE FRONT OF THE STRUCTURE TO PROVIDE THE SHORTEST, MOST DIRECT ROUTE FROM THE BUILDING TO THE EXISTING LATERAL STUB.

NOTE: CONCRETE APRON AND CASTING SHALL BE INSTALLED SO THAT THEY DO NOT CONTACT THE LATERAL OR LATERAL CAP. EAST JORDAN IRONWORKS MODEL 1755 CASTING, LETTERED "SEWER" SHALL BE USED.

NOTE: ALL CLEANOUT PIPE AND FITTINGS TO BE PVC SCHEDULE 40 OR SDR 35 WHEN SHALLOWER THAN TWELVE (12) FEET. AT DEPTHS GREATER THAN TWELVE (12) FEET MATERIAL OF CONSTRUCTION WILL BE DETERMINED BY ENGINEER.

NOTE: TOP OF CASTING OR CLEANOUT CAP SHALL EXTEND 0.20 FEET MINIMUM ABOVE FINISHED GRADE UNLESS CONSTRUCTED WITHIN PEDESTRIAN OR VEHICULAR TRAFFIC WAY. UNLESS APPROVED BY ENGINEER, SANITARY SEWER CASTINGS OR CLEANOUTS MUST NOT BE WITHIN ONE (1) FOOT HORIZONTAL DISTANCE OF ANY PAVED OR CONCRETE SURFACES.

TYPICAL CLEANOUT DETAILS

FIGURE 1-3

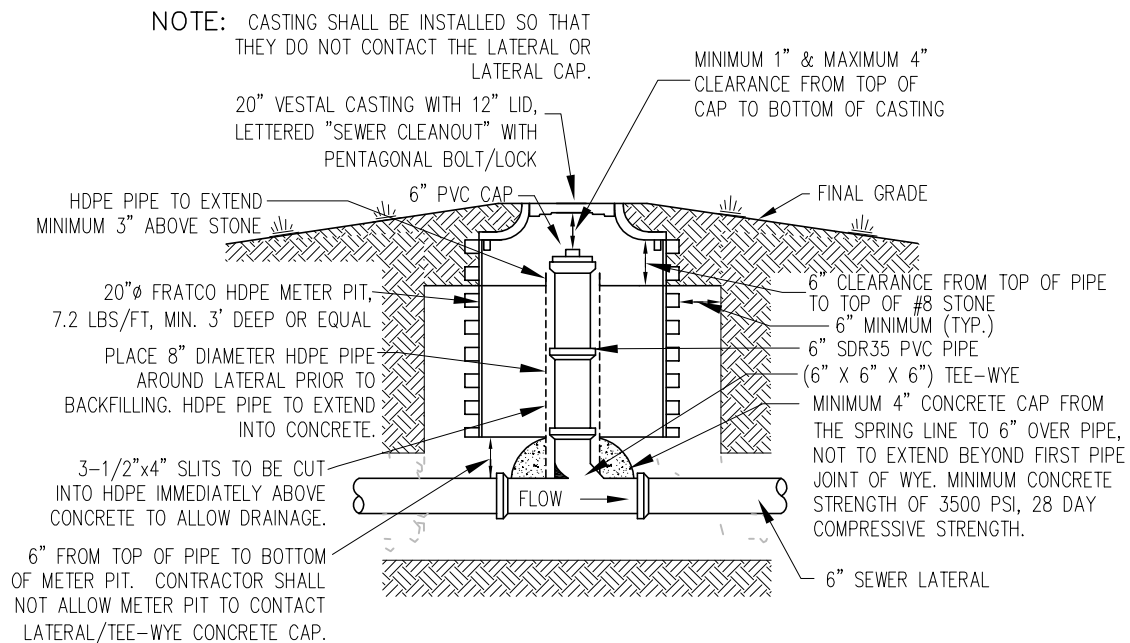

CLEANOUT TYPE 3

(GRASS OR LANDSCAPE SURFACES BEYOND THREE FEET OF BUILDING)

NOTE: TOP OF CASTING OR CLEANOUT CAP SHALL EXTEND 0.20 FEET MINIMUM ABOVE FINISHED GRADE UNLESS CONSTRUCTED WITHIN PEDESTRIAN OR VEHICULAR TRAFFIC WAY. UNLESS APPROVED BY ENGINEER, SANITARY SEWER CASTINGS OR CLEANOUTS MUST NOT BE WITHIN ONE (1) FOOT HORIZONTAL DISTANCE OF ANY PAVED OR CONCRETE SURFACES.

NOTE: ALL CLEANOUT PIPE AND FITTINGS TO BE PVC SCHEDULE 40 OR SDR 35 WHEN SHALLOWER THAN TWELVE (12) FEET. AT DEPTHS GREATER THAN TWELVE (12) FEET MATERIAL OF CONSTRUCTION WILL BE DETERMINED BY ENGINEER.

TYPICAL CLEANOUT DETAIL

FIGURE 1-4

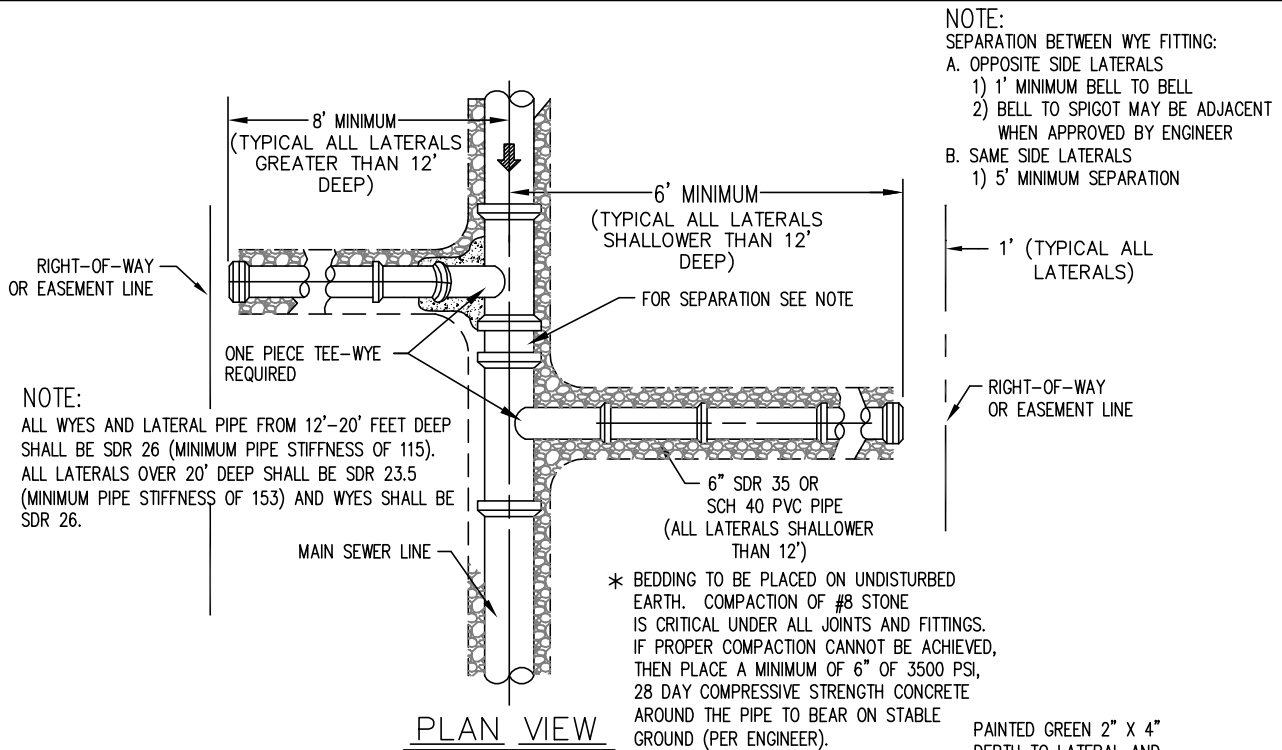

PLAN VIEW

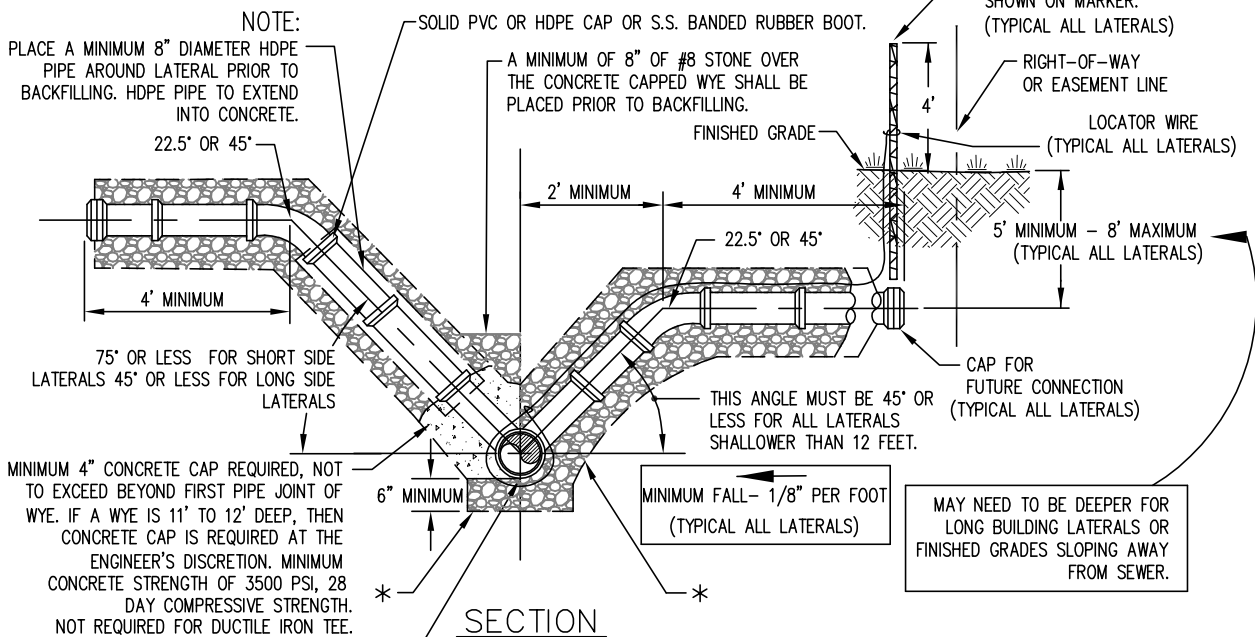

SECTION

MORE THAN 12' DEEP

LESS THAN 12' DEEP

NOTE: IF THE SEWER IS DEEPER THAN 25 FEET THEN THE PIPE FOR BOTH LONG SIDE AND SHORT SIDE MAY NOT BE LAID AT A SLOPE GREATER THAN 45 DEGREES.

NOTE: DEPTH OF SERVICE LATERAL SHALL BE MEASURED FROM FINISHED GRADE TO THE TOP OF MAIN SEWER LINE.
ALL PIPING FROM WYE TO 45'/22' FITTING AT 5'-8' BELOW GRADE SHALL BE SDR 26 TO 20' DEEP OR SDR 23.5 GREATER THAN 20' DEEP.

SERVICE LATERAL DETAIL

FIGURE 1-5

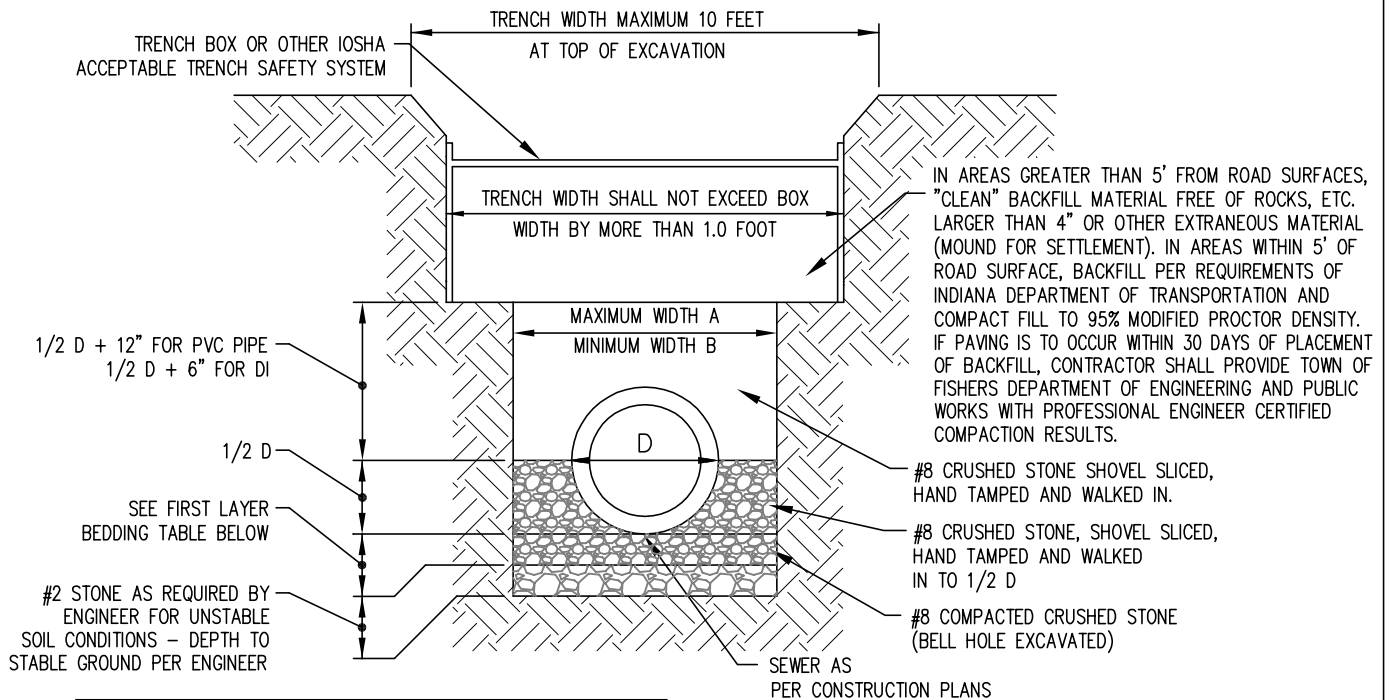

| FIRST LAYER BEDDING TABLE | | |
|--|--------------|---------------|
| PIPE SIZE | 6" TO 15" | 18" & OVER |
| BEDDING BELOW THE PIPE BARREL AND BELL | MINIMUM = 6" | MINIMUM = 10" |

| PIPE SIZE | A | B |
|-----------------|---------|---------|
| UP TO 18" | 3'-0" | 2'-6" |
| 18" AND GREATER | D + 24" | D + 18" |

SANITARY SEWER TRENCHING, BEDDING AND BACKFILL DETAIL

FIGURE 1-6

Hamilton Southeastern Utilities, Inc.

Application For Sewer Connection

317-577-2300

| | |
|------------------|----------------------|
| Office Use Only: | Sewer Permit # _____ |
| | Sewer Acct # _____ |

Builder _____
Name Phone

Builder's Address _____
Street City/Zip

Lot Location _____
Lot No. Development Section

Lot Address _____
Street City/Zip

Building Sewer/Lateral Contractor _____

A. Usage SFR MFR Non-Residential Special User Municipal Other

B. Description of Facility _____

C. EDU Allocation/Estimated daily gallonage _____ Floating EDU

D. Type of Improvement New Remodel Existing Finished Floor Elevation _____

E. Sump Pump Yes No Grinder Pump/Effluent Pump Yes No

F. Roof run-off, floor drains & sub-surface drainage to:

Ground Surface Storm Sewer Other (Explain) _____

G. Cooling water or geothermal system discharge to:

Ground Surface Storm Sewer Not Applicable Other (Explain) _____

I hereby represent and certify that I have the authority and am fully empowered to make the foregoing application, that the application and accompanying plot plan are true and correct, and that all construction of sanitary sewer will comply with all rules, regulations, standards, and specifications currently adopted by Hamilton Southeastern Utilities, Inc. I further certify that storm water (i.e. downspouts, sump pump, surface water drainage, etc.) shall not enter the sanitary sewers and that no connections to sewer mains will be made without inspection and approval of Hamilton Southeastern Utilities, Inc.

The covenants and stipulations herein provided shall extend to and be binding upon the respective heirs, successors and assigns of the location to which sewer service is provided as described herein.

Signature of Builders Authorized Agent _____

| | | |
|--|--|------------|
| OFFICE USE ONLY: | | |
| Application Approved by _____ | Permit Fees Total _____ | Date _____ |
| (Non-Refundable) | | |
| Subsequent Connector: <input type="checkbox"/> Yes <input type="checkbox"/> No | PERMIT VALID FOR ONE YEAR FROM DATE OF ISSUANCE | |

WHITE - HAMILTON SOUTHEASTERN COPY

YELLOW - APPLICANTS COPY

PINK - BUILDING PERMIT

APPENDIX B

HAMILTON-SOUTHEASTERN UTILITIES, INC.

PLOT PLAN STANDARDS

1. Name of the company that prepared the plot plan.
2. Date of drawing/revision dates.
3. Subdivision name/section/lot number.
4. Street address of home/building.
5. North arrow and scale.
6. All drawings must be drawn to scale and plotted with a horizontal scale of 1" = 10', 20', 30', 40', 50' or 60'. **Note:** The scale of the plot plan shall present the information clearly and allow HSE the ability to scale dimensions. If HSE has difficulty scaling dimensions or reading the data, then HSE may request that the plot plan be re-plotted at a different scale.
7. All drawings must be submitted on letter or legal size paper. For more complex projects 24" x 36" sheets will be acceptable.
8. All dimensions, distances, elevations, etc. shall be displayed in English units.
9. Entire boundary of lot or parcel with dimensions labeled per recorded plat or deed. **Note:** If the lot or parcel is not platted, provide the recording information of the deed.
10. Easements, building lines and right-of-ways per recorded plat. **Note:** If the parcel is not platted, provide pertinent information from the zoning requirements. (i.e., building set back requirements, etc.)
11. Graphically indicate all revisions due to certificates of correction and provide the recording information.
12. Graphically indicate all easements and right-of ways recorded against the deed and provide the recording information.
13. Elevation of the first floor **and** lowest point of gravity service (if other than the finished floor elevation).
14. As-built top of casting elevation of the nearest upstream **and** downstream sanitary sewer manhole. **Note:** Do not provide the top of casting elevation of sanitary sewer manholes installed with bolted and gasketed castings, instead label the manhole as having a "bolted casting." Contact HSE to discuss the specific situation in more detail. **Manholes with bolted and gasketed castings can not be used as a relief manhole.**

15. The plot plan must comply with and indicate the following note, “The lowest elevation to have gravity sanitary sewer service must be more than one (1) foot above the lowest top of casting elevation of either the first upstream or downstream manhole on the main line sewer to which the connection is to be made.” **Note:** If the vertical separation can not be maintained, then the home or building owner must install *either an I&A Tank or a grinder/effluent pump*.
16. All elevations on the Plot Plan must be on the same vertical datum as the HSE approved construction plans. **Note:** Record drawings created for HSE are typically prepared on the NAVD 1988 vertical datum; therefore, the entity preparing the plot plan should consider that as-built elevations may be on a different vertical datum. Conversions between different datum may be necessary.
17. Provide the as-built location of the upstream and downstream manholes, the sanitary sewer main to which the building sewer connects and the wye/lateral. Provide the entire route of the building sewer with all Type 1/2/3 clean-outs identified. **Note:** Clean-outs installed in grass or landscape areas **and** located within three (3) feet of the buildings exterior wall can be installed as Type 1 clean-outs. All other clean-outs must be installed as Type 3 clean-outs, except hardscape surfaces require a Type 2 clean-out. *The Top of Casting (TC) must be shown for both Type 2 and Type 3 clean outs.*
18. Provide the location of all proposed or existing sanitary sewer facilities contained within the boundary of the lot or parcel including, gravity sewers and manholes, lift stations (wet well and valve vault), individual grinder stations, I & A tanks, force mains, force main fittings, isolation/service valves, air/vacuum relief manholes, force main or lateral (Type 1, 2 or 3) clean-outs, grease traps, grit traps, oil/water separators, neutralization tanks, end of stubs (no matter the length of the stub), etc. If more than one wye/lateral exists on the site, identify which lateral is to be abandoned.
19. Indicate the lateral size as a minimum of six (6) inches in diameter, except I & A tanks shall be (4) four inch diameter.
20. *The proposed elevation of the lid (“TC”) for I&A Tanks or grinder/ effluent pumps must be shown.*
21. All sanitary sewer manhole top of casting (TC) elevations and sanitary sewer/lateral locations indicated on the plot plan will be considered as as-built information unless otherwise noted. HSE will not permit “plan” information, but if this information is permitted then it must be labeled as “plan.” **Note:** *If plan information is permitted, the F.F.E must be at least two (2) feet above the lower TC elevation of either the first upstream or downstream manhole on the main line sewer to which the connection is to be made.*
22. *When extending service laterals to the house connection point the lateral must be a minimum of five feet from the face of the structure (both house and garage) for portions of the lateral that parallels the structure. The lateral must be a minimum of three feet from the face of a porch if it is adjacent.*
23. *When laterals are extended into side yards a ten (10) separation between the lateral and the lot line must be maintained. If this separation can not be maintained an additional easement must be granted on the adjoining lot.*

24. Home/building and out-buildings dimensioned and tied down.
25. Center line of adjoining streets with street names.
26. Driveway, sidewalk and curb line locations. **Note:** *Pavement or concrete, including driveways and sidewalks, must not be constructed on or within one (1) foot horizontal distance of any sanitary sewer casting. The only exception is a Type 2 Cleanout casting in a sidewalk.*
27. If applicable, the proposed sump pump/roof drain connection into the sub-surface drain. **Note:** HSE does not permit clear water sources (foundation drains, sump pumps, roof drains, etc.) to discharge into the sanitary sewers.
28. For *all* homes or buildings:
 - a. The plot plan shall be prepared and electronically submitted to HSE on *PDF format or AutoCAD Release 14 (or higher)* or be capable of being converted to a DXF file. If this presents a problem, then contact HSE to discuss possible alternatives.
 - b. Indicate well and septic field locations.
 - c. Identify the location(s) at which the plumbing exits the home/building.
29. If the building sewer involves construction of a force main then include HSE's Small Diameter Specifications sheet and either HSE's Common Force Main Details sheet or Grinder Pump Details sheet. These documents can be found at the download zone of HSE's web page – www.hseutilities.com.
30. For further information regarding building sewers refer to HSE's "Standards for Design and Construction of Building Sewers (Laterals)."